

TDS No.019

SET for High Intensity Discharge lamps, type HSI 100W 230V 50Hz with thermal protection

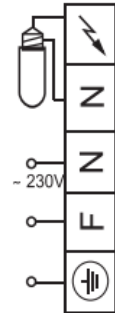
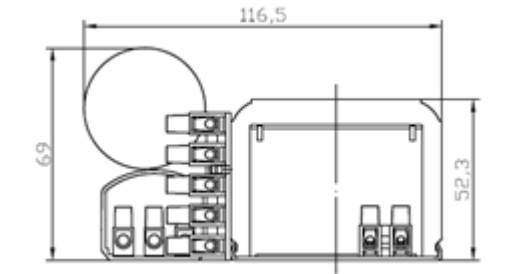
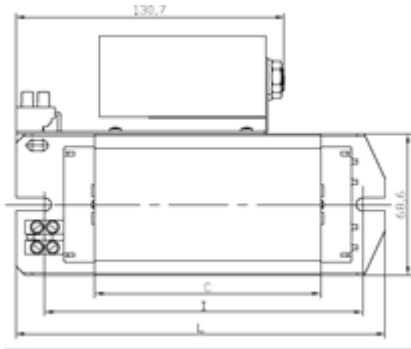

Reference		Assembly Kits for High-pressure sodium vapour lamps
Type		HSI 100W 230V 50Hz
Ref.No	-	4.53.53.101
Art.No.	-	92053101
Rated power	W	100
Rated voltage	V	230 AC , 50Hz
Rated current	A	1.20
Power factor	-	> 0.90
Energy Efficiency (EEI)	-	A3
Short circuit current at 1.06Un	A	< 2.40
Compensation Capacitor	µF	13
Type of protection	-	integral, automatic resetting (cyclic) type
Independent Ignitor	-	superimposed system
Temperature rise normal (dt)	°C	75
Maximum winding temperature (tw)	°C	130
Weight	kg	1.60
Dimensions:	-	-
C	mm	36
I	mm	87
L	mm	112
Luminaire terminal block: screw terminals	mm ²	2.5
Permissible load capacity	pF	20 ÷ 100

ELECTROSTART
 SHAREHOLDERS COMPANY
 VURSHETS
 BULGARIA

In accordance with IEC 61347-1, IEC 61347-2-9, IEC 62442-2, IEC 60923, IEC 60927 and IEC 60662.