

TDS No.020

SET for High Intensity Discharge lamps, type HSIP /MHIP 150W 230V 50Hz **with thermal protection**

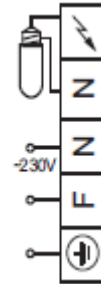
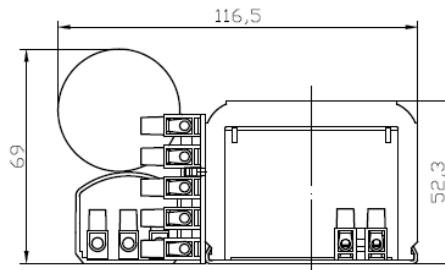
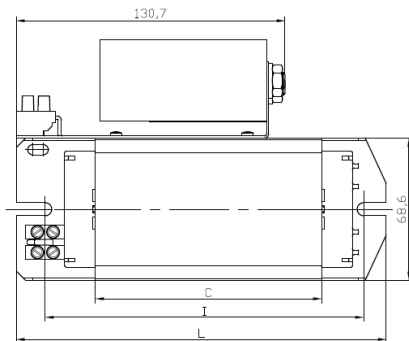

Reference		Assembly Kits for High-pressure sodium vapour and Metal-halide lamps
Type		HSIP/MHIP 150W 230V 50Hz
Ref.No	-	4/7.53.53.151
Art.No.	-	92053151
Rated power	W	150
Rated voltage	V	230 AC , 50Hz
Rated current	A	1.80
Power factor	-	> 0.90
Energy Efficiency (EEI)	-	A3
Short circuit current at 1.06Un	A	< 3.00
Compensation Capacitor	μF	20
Independent Ignitor	-	superimposed system
Type of protection	-	integral, automatic resetting (cyclic) type
Temperature rise normal (dt)	°C	75
Maximum winding temperature (tw)	°C	130
Weight	kg	2.33
Dimensions:	-	-
C	mm	64
I	mm	120
L	mm	145
Luminaire terminal block: screw terminals	mm ²	4.00
Permissible load capacity	pF	20 ÷ 100

ELECTROSTART
 SHAREHOLDERS COMPANY
 **VURSHETS**
BULGARIA

In accordance with IEC 61347-1, IEC 61347-2-9 , IEC 62442-2, IEC 60923 , IEC 60927 and IEC 60662 .